

1114 TS Foundation Rig



1114 TS(X) Technical Data

ENGINE

Diesel Engine	Deutz TCD 6.1 L6
Power	180 kW
Tractive power	25 000 kg
Shoe width	500 mm
Weight std. type from	15 000 kg

FEEDER

Feed length	4 000 mm
Feeder force	6 000 kg
Pull up	14 000 kg
Mast winch	750 kg
Drill table	Ø520 mm
Feed Extention	1 500 mm
Rapid feed	0,30 m/sec
Rapid pull up	0,30 m/sec
Pipe wrench cylinder	Ø 90 mm

ROTATION UNIT

Torque	8000/16000 Nm
Rotation speed	0-75 / 0-37 rpm
Spindel thread API 2	API2 - 7/8"IF

OTHER

Oscillation	+15, -15 gr
Speed track	2,5 / 4,0 km/h
Battery	2 x 50 Ah dry
Hydr. tank	430 L
Diesel Tank	360 L

OPTIONAL EQUIPMENT

Main winch 6000 kg.
 Welding machine
 Different types of water pumps and water tanks
 Diverter housing
 Pipe rack
 Crane 2,7 tm alt. 4 tm, radiocontrolled
 Other equipment delivered acc. to agreement

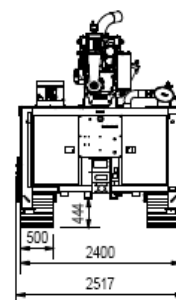
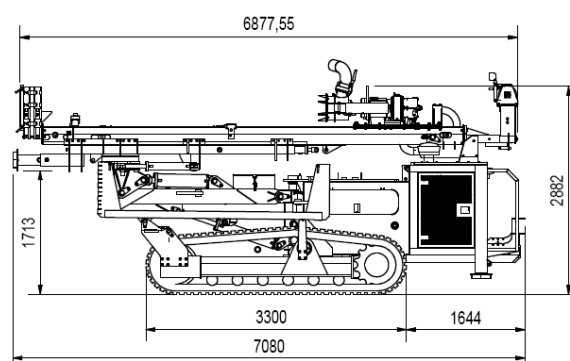

From the very first Qmatec /Nemek produced rig in 1966, our rigs have been developed and improved in close collaboration with visionary customers. Our employees have long experience and are proud of their profession. Our service people are available where you are, 24-hours a day. This ensures quality throughout the entire process and helps you to be profitable every day – year after year.



1114 TS(X)
www.qmatec.no
 Additional technical data
 More pictures

Qmatec Drilling AS

Verkstadvegen 12, 3890 VINJE

Phone: +47 35063400

E-mail: mail@qmatec.com

Web.page: www.qmatec.no